



ESTUN AUTOMATION CO.,LTD.

📍 No.1888, Jiyin Road, Jiangning Development Zone, Nanjing city
No.16, Shuige Road, Jiangning Development Zone, Nanjing city
No.178, Yanhu Road, Jiangning Development Zone, Nanjing city
☎ +86-25-52785866
📠 +86-25-52785966
🏠 www.estun.com



Official wechat



Official website

Service Hotline +86 400 025 3336

Summa ED3L series full digital AC servo system



ALL DIGITAL AC SERVO SYSTEMS

ESTUN AUTOMATION Co., Ltd. is a leading supplier and service provider of high-end automation core components and industrial robots and intelligent manufacturing systems in China.

As one of the influential enterprises in the field of motion control in China, Estun has completed the strategic transformation of its product line of automation core components from AC servo system to motion control system solutions, and its business model is fully sublimated from single axis, single machine and single unit.

Estun has actively explored the "internationalization" development strategy, successively purchased Trio from the UK and controlled M.A.I from Germany. The company invested in Barrett of America, Euclid of Italy and other companies, and established a European RESEARCH and development center in Milan, which initially completed the international layout in brand and technology, laying a solid foundation for the company to implement the development strategy in motion control solutions, intelligent collaborative robots, rehabilitation robots and industry 4.0. At present, Estun Automation has 7 overseas branches in the world, and its business covers more than 60 countries and regions.

In the future, Estun will follow the development trend of the industry, walk out a development road with Estun characteristics, take the motion control system as the first brand in China, take the mission of creating the world brand of Chinese robot, and build Estun into an international enterprise recognized and respected by peers.

A beautiful world, worthy of all our efforts

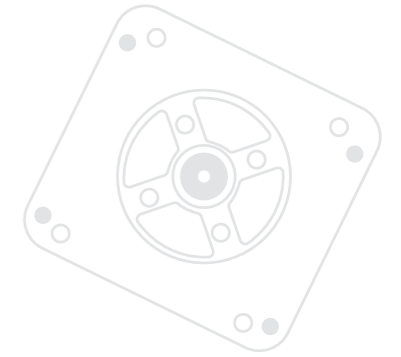

Servo drive & Servo motor 03

Part Numbers 13

Accessories 17

CONTENTS

01 Servo drive & Servo motor



ED3L - 04 A E A - FS01

ED3L Servo drive

Rated output power

Voltage grade

Options

Encoder type

Extended function



A5	0.05kW
01	0.1kW
02	0.2kW
04	0.4kW
08	0.75kW
10	1.0kW
15	1.5kW
20	2.0kW
30	3.0kW
50	5.0kW
75	7.5kW

A	200VAC
D	400VAC

E	EtherCAT
M	CANopen,pulse
P	Profinet

A	Serial encoder
C	Linear encoder

FS01 Support the STO

Note: 1, Please refer to "Model Comparison Table" for details.
2, Only ED3L-04AEC and ED3L-10AEC support linear motors
3, The default model does not contain extended functions

200VAC

Driver model:ED3L-	A5A	01A	02A	04A	08A	10A	15A	20A
Continuous output current[Arms]	0.9	1.1	1.5	2.9	5.1	6.9	9.5	12.6
Maximum output current[Arms]	3.3	4.0	5.8	11.5	19.5	21.0	31.6	42.0
Capacity of main power supply[kVA] (Single phase)	0.2	0.3	0.6	1.2	1.9	2.6	4.0	-
Capacity of main power supply[kVA] (Three-phase)	-	-	-	-	1.6	2.0	3.0	3.5

400VAC

Driver model:ED3L-	10D	15D	20D	30D	50D	75D
Continuous output current[Arms]	3.6	5.0	7.1	12.0	17.0	27.3
Maximum output current[Arms]	10.9	16.3	21.2	36.6	53.0	70.0
Capacity of main power supply[kVA] (Three-phase)	1.8	2.8	3.5	5.0	8.2	12.0

Single axis, 200VAC , Rated power: 50W~400W

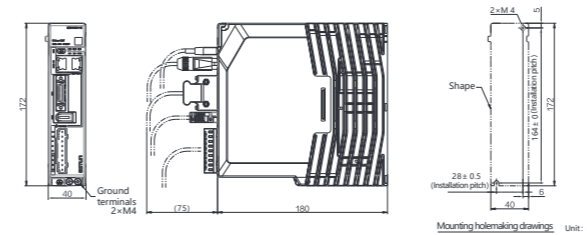

Single axis, 200VAC , Rated power: 750W~1KW

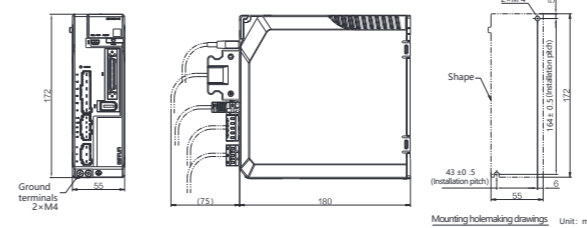

Single axis, 200VAC , Rated power: 1.5kW~2KW

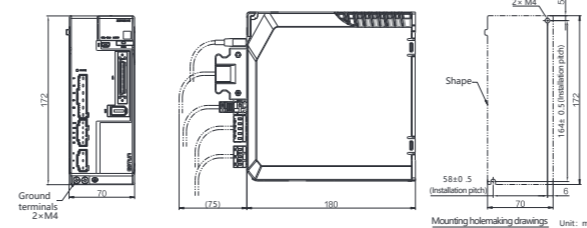

Single axis, 400VAC , Rated power: 1kW~1.5KW

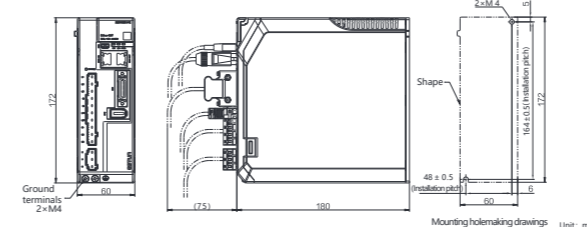

Single axis, 400VAC , Rated power: 2kW~3KW

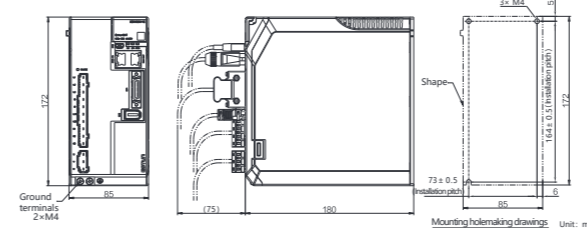

Single axis, 400VAC , Rated power: 5kW~7.5KW

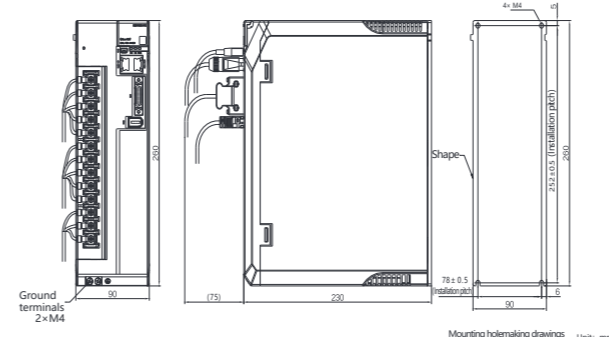

General specification	Description	
Input power	200VAC	Single-phase AC 200V to 240VAC 200V ~ 240V, -15% ~ +10%, 50Hz/60Hz Three-phase AC 200V ~ 240V, -15% ~ +10%, 50Hz/60Hz (Power ≥ 0.75kw)
	400VAC	Three-phase AC 380V ~ 440V, -15% ~ +10%, 50Hz/60Hz
Operation conditions	Work environment	Temperature: When used on a single device: -5°C ~ 55°C; When multiple devices are installed snugly: -5°C ~ 40°C Humidity: 5% to 95% (with no condensation)
	Storage environment	Temperature: -20°C ~ 85°C Humidity: 5% to 95% (with no condensation)
	Protection Class	IP20
	Altitude	Below 1000 m
Performance	Vibration resistance	Vibration Resistance: 4.9m/s ² ; Shock Resistance: 19.6m/s ²
	Impact resistance	Shock Resistance: 19.6m/s ²
Installation structure	Base-mounted	
Soft start time setting	Coefficient of speed fluctuation	±0.01% of rated speed max. (For a load fluctuation of 0% to 100%) 0% of rated speed max. (For a load fluctuation of ±10%) ±0.1% of rated speed max. (For a temperature fluctuation of 25°C±25°C)
	Soft start time setting	0 s to 10 s (Can be set separately for acceleration and deceleration.)
	USB communication	Conforms to USB2.0 standard (12 Mbps)
Display	5 bit digital tube	
Panel operator	4 Buttons	
Regenerative braking	50W ~ 400W products without built-in brake resistance Other power products have built-in brake resistance	
Protection function	Overcurrent, Overvoltage, Undervoltage, Overload, Regeneration Error, Overspeed, etc.	
Utility Functions	Alarm recording, JOG running, load inertia recognition, mechanical analyzer, automatic setting tools, etc	

Bus type specifications	Description
Power range	50W~7.5kW
I/O Signals	Input Signals: Allowable voltage range: 24 VDC±20% Number of input points: 5 (Two fixed channels can be used for Touch Probe)
	Output Signals: Operating voltage range: 5 VDC to 30 VDC Number of output points: 3 (1 of them fixed for Servo Alarm)
Communications and Standards	Standard EtherCAT/ProfiNet protocol and rules

Pulse type specifications	Description
Power range	50W~7.5kW
I/O Signals	Encoder pulse division output: A-phase, B-phase, C-phase: line drive output Number of divider pulses: Arbitrary frequency division
	Input Signals: Operating voltage range: 24 VDC±20% Number of input points: 10 (Two fixed channels can be used for Touch Probe)
Torque Control	Output Signals: Operating voltage range: 5 VDC to 30 VDC Number of output points: 4 (1 of them fixed for Servo Alarm)
	External input: DC± 10V (DC± 0V ~ ± 10V: Variable setting range)
Speed control	Built-in set: 4 torque contacts
	External input: DC± 10V (DC± 0V ~ ± 10V: Variable setting range)
Position control	Built-in set: Speed 1 to Speed 7
	External input: Choose one of the following input types Symbol + Pulse Column; CCW + CW Pulse Column; 90° Phase Difference 2 Phase Pulse (A Phase + B Phase)
Built-in set	32 location contacts

linear drive	Description
Power range	100W~1.0kW
I/O Signals	Input Signals: Allowable voltage range: 24 VDC±20% Number of input points: 5
	Output Signals: Allowable voltage range: 5 VDC to 30 VDC Number of output points: 3 (One of the fixed channels is used for servo alarm)
Encoder	Pulse signal: A, B, Z (Difference) Hall signal: 5V single-ended signal
Communications & Standards	Standard EtherCAT protocol and rules

EM3A servo motor(50W ~ 1.0kW)

Small capacity | High speed | Low inertia

EM3A – 04 A L A 2 4 1



Rated output power	Voltage grade	encoder	Design order	Shaft end	Optional	Plug type
A5 0.05kW 01 0.1kW 02 0.2kW 04 0.4kW 08 0.75kW 10 1.0kW	A 200VAC	T 17-bits absolute L 23-bits absolute	A -	2 Straight, with keys, Threaded	1 No oil seals, No brakes 2 With oil seal, No brakes 3 No oil seals, With brake 4 With oil seal, With brake	1 Standard plugs 2 Waterproof plug

Note: 1. Please refer to "Model Comparison Table" for details.
2. Motor body heat resistance class: F
3. Motor body protection mode: self-cooling, IP65/IP67

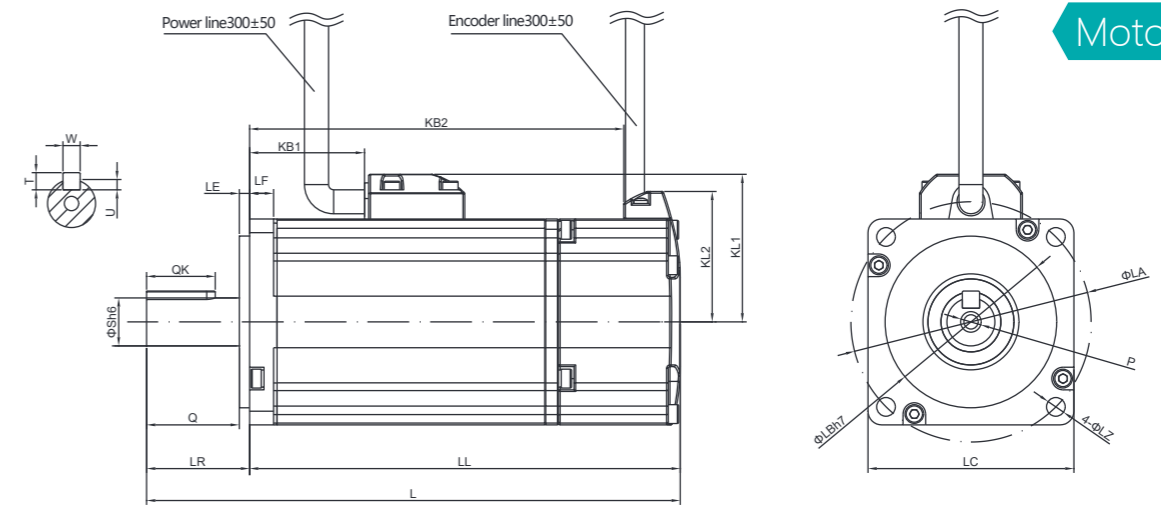

Motor size

Power	EM3A-	L	LL	KB1	KB2	KL1	KL2	Flange Dimensions						S	P	key					
								LR	LE	LF	LC	LA	LB			LZ	QK	Q	W	T	U
50W	A5AL	87.5 (121)	62.5 (96)	19.8(32.8)	48.3(81.8)	33	33	25	2.5	5	40	46	30	4.3	8	M3× 6	14	22	3	3	1.8
100W	01AL	103.5(137)	78.5 (112)	35.8(48.8)	64.3(97.8)	33	33	25	2.5	5	40	46	30	4.3	8	M3× 6	14	22.5	3	3	1.8
100W	01AT	113.5(147)	88.5(122)	35.8(48.8)	74.3(107.8)	33	33	25	2.5	5	40	46	30	4.3	8	M3× 6	14	22.5	3	3	1.8
200W	02AL	108 (137)	78 (107)	27.5(33.5)	61.5(90.5)	43	38	30	3	7	60	70	50	5.5	14	M5× 12	20	27	5	5	3
200W	02AT	126.5(155.5)	96.5(125.5)	42.7(48.7)	80 (109)	43	38	30	3	7	60	70	50	5.5	14	M5× 12	20	27	5	5	3
400W	04AL	129 (158)	99 (128)	48.5(54.5)	82.5(111.5)	43	38	30	3	7	60	70	50	5.5	14	M5× 12	20	27	5	5	3
400W	04AT	147.5(176.5)	117.5(146.5)	48.5(54.5)	101(130)	43	38	30	3	7	60	70	50	5.5	14	M5× 12	20	27	5	5	3
750W	08AL	151 (184)	111(144)	58.2(59.2)	35.8(67.8)	53	48	40	3	8	80	90	70	6.6	19	M6× 12	25	37/35	6	6	3.5
750W	08AT	167.5(200.5)	127.5(160.5)	58.2(59.2)	52.3(84.3)	53	48	40	3	8	80	90	70	6.6	19	M6× 12	25	37	6	6	3.5
1.0kW	10AL	165 (198)	125(158)	72.2(73.2)	35.8(67.8)	53	48	40	3	8	80	90	70	6.6	19	M6× 12	25	37	6	6	3.5
1.0kW	10AT	181.5(214.5)	141.5(174.5)	72.2(73.2)	34.3(56.3)	53	48	40	3	8	80	90	70	6.6	19	M6× 12	25	37	6	6	3.5

Note: The values in parentheses represent the values of motors with brakes.

		200VAC												
EM3A-		A5A	01A	02A	04A	08A	10A							
Flange [mm]		40	40	60	60	80	80							
Rated power [kW]		0.05	0.1	0.2	0.4	0.75	1.0							
Rated speed[r/min]		3000	3000	3000	3000	3000	3000							
Maximum speed [r/min]		6000	6000	6000	6000	6000	6000							
Rated torque [N·m]		0.159	0.318	0.637	1.27	2.39	3.18							
Maximum torque [N·m]		A5AL	01AT	01AL	02AT	02AL	04AT	04AL	08AT	08AL	10AT	10AL		
		0.557	0.954	1.11	1.91	2.23	3.81	4.46	7.17	8.37	9.54			
Rated current [Arms]		0.9	1.1	1.5	2.9	5.1	6.9							
Maximum current [Arms]		A5AL	01AT	01AL	02AT	02AL	04AT	04AL	08AT	08AL	10AT	10AL		
		3.3	3.5	4	4.7	5.8	9.2	11.5	16.1	19.5	21			
Motor inertia [10 ⁻⁴ kg·m ²]		0.023(0.0268)	0.0428(0.0465)	0.147(0.179)	0.244(0.276)	0.91(1.07)	1.14(1.30)							
Allowable shaft end load	Radial[N]	78	78	245	245	392	392							
	Axial[N]	54	54	74	74	147	147							
Brake specification	Rated voltage	24VDC	24VDC	24VDC	24VDC	24VDC	24VDC							
	Holding torque[N·m]	≥0.32	≥0.32	≥1.5	≥1.5	≥3.2	≥3.2							
Weight[kg]		0.4(0.6)	0.5(0.7)	0.9(1.3)	1.3(1.7)	2.6(3.2)	3.1(3.8)							

Note: The values in parentheses represent the values of motors with brakes.

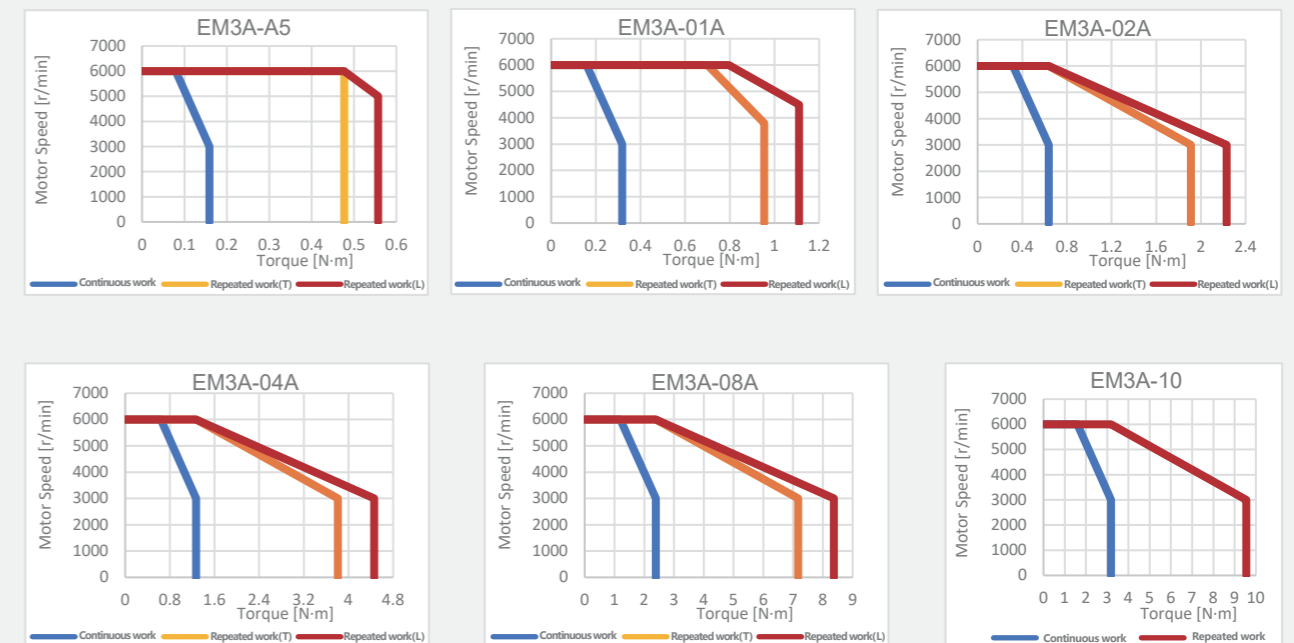

Note: T represents a 17-bits absolute
L represents a 23-bits absolute

EM3A servo motor(1.5kw ~5kW)

Medium capacity | High speed | Low inertia

Motor size

EM3A – 15 A L B 2 2 4



Rated output power

15	1.5kW
20	2.0kW
30	3.0kW
40	4.0kW
50	5.0kW

Voltage grade

A	200VAC
D	400VAC

encoder

T	17-bits absolute
L	23-bits absolute

Design order

A	-
---	---

Shaft end

2	Straight, with keys, Threaded
---	-------------------------------

Optional

1	No oil seals, No brakes
2	With oil seal, No brakes
3	No oil seals, With brake
4	With oil seal, With brake

Plug type

4	Aviation Plug
---	---------------

Note: 1. Please refer to "Model Comparison Table" for details.
2. Motor body heat resistance class: F
3. Motor body protection mode: self-cooling, IP65/IP67

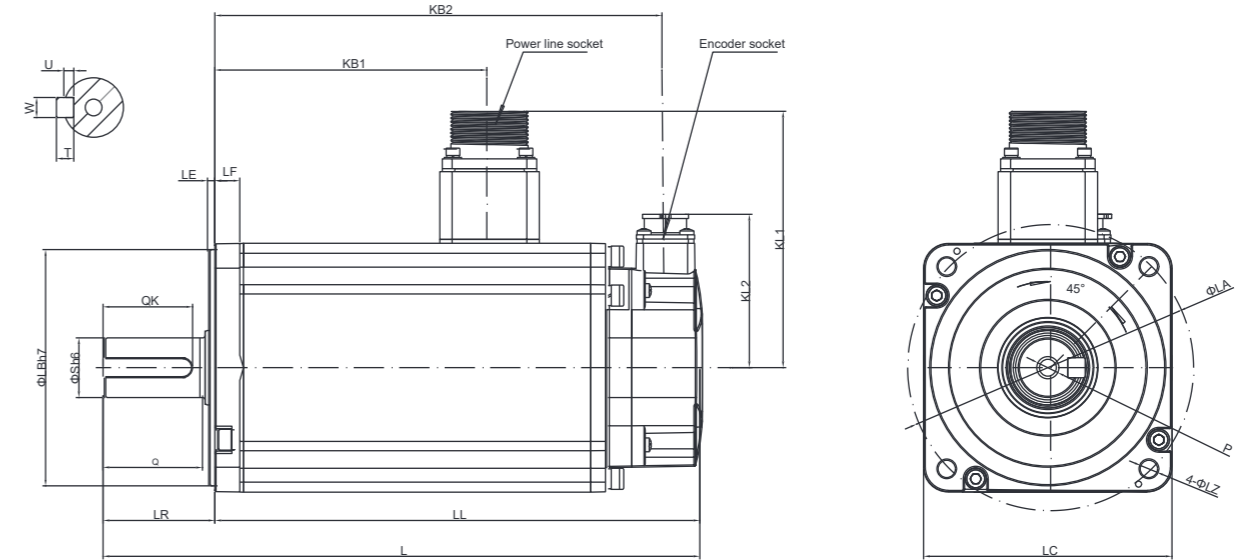

EM3A-	200VAC		400VAC					
	15A	20A	15D	20D	30D	40D	50D	
Flange [mm]	100	100	100	100	130	130	130	
Rated power [kW]	1.5	2.0	1.5	2.0	3.0	4.0	5.0	
Rated speed [r/min]	3000	3000	3000	3000	3000	3000	3000	
Maximum speed [r/min]	5000	5000	5000	5000	5000	5000	5000	
Rated torque [N·m]	4.78	6.37	4.78	6.37	9.80	12.8	15.9	
Maximum torque [N·m]	14.3	19.1	14.3	19.1	29.4	38.4	47.7	
Rated current [Arms]	9.5	12.6	4.9	6.4	10.5	13.0	15.9	
Maximum current [Arms]	31.6	42.0	16.3	20.5	33.0	40.0	50.0	
Motor inertia [10 ⁻⁴ kg·m ²]	2.33(3.10)	2.95(3.72)	2.33(3.10)	2.95(3.72)	7.72(9.00)	10.2(11.6)	14.0(15.4)	
Allowable shaft end load	Radial [N]	686	686	686	686	980	980	980
	Axial [N]	196	196	196	196	392	392	392
Brake specification	Rated voltage	24VDC	24VDC	24VDC	24VDC	24VDC	24VDC	24VDC
	Holding torque [N·m]	≥8	≥8	≥8	≥8	≥20	≥20	≥20
Weight [kg]	5.1(6.4)	6.1(7.5)	5.1(6.4)	6.1(7.5)	10.0(12.0)	12.0(14.0)	15.5(17.5)	

Note: The values in parentheses represent the values of motors with brakes.

Power	EM3A-	L	LL	KB1	KB2	KL1	KL2	Flange Dimensions							S	P	key				
								LR	LE	LF	LC	LA	LB	LZ			QK	Q	W	T	U
1.5kW	15□	210(240)	165(195)	97(109)	150(180)	102	60	45	3	10	100	115	95	7	24	M8×16	36	40	8	7	4
2.0kW	20□	230(260)	185(215)	117(129)	170(200)	102	60	45	3	10	100	115	95	7	24	M8×16	36	40	8	7	4
3.0kW	30D	257(289.5)	194(226.5)	160.5	179(211.6)	110	60	63	6	12	130	145	110	9	28	M8×16	54	55	8	7	4
4.0kW	40D	284(316.5)	221(253.5)	187.5	206(238.5)	110	60	63	6	12	130	145	110	9	28	M8×16	54	55	8	7	4
5.0kW	50D	324(356.5)	261(293.5)	227.5	246(278.5)	110	60	63	6	12	130	145	110	9	28	M8×16	54	55	8	7	4

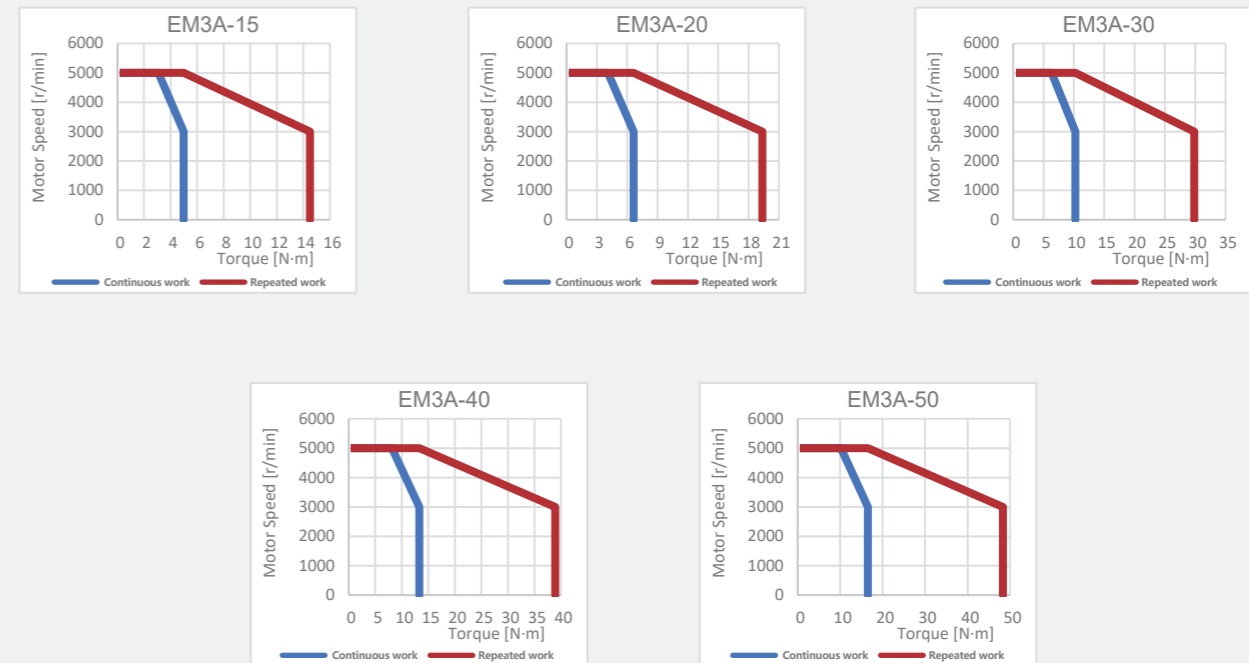

Note: T represents a 17-bits absolute
L represents a 23-bits absolute

EM3J servo motor (200W ~ 1.0kW)

Small capacity | High speed | Medium inertia

EM3J - 04 A L A 2 4 2



Rated output power	Voltage grade	encoder	Design order	Shaft end	Optional	Plug type
02 0.2kW	A 200VAC	T 17-bits absolute	A -	2 Straight, with keys, Threaded	1 No oil seals, No brakes	1 Standard plugs
04 0.4kW	D 400VAC	L 23-bits absolute			2 With oil seal, No brakes	2 Waterproof plug
08 0.75kW					3 No oil seals, With brake	
10 1.0kW					4 With oil seal, With brake	

Note: 1. Please refer to "Model Comparison Table" for details.
 2. Heat resistance grade of motor body: F
 3. Motor body protection mode: self-cooling, IP65

	200VAC						400VAC	
	02A	04A	08A	10A	10D			
EM3J-	02A	04A	08A	10A	10D			
Flange [mm]	60	60	80	80	80			
Rated power [kW]	0.2	0.4	0.75	1.0	1.0			
Rated speed [r/min]	3000	3000	3000	3000	3000			
Maximum speed [r/min]	6000	6000	6000	6000	6000			
Rated torque [N·m]	0.637	1.27	2.39	3.18	3.18			
Maximum torque [N·m]	02AT	02AL	04AT	04AL	08AT	08AL	10AT/L	10DT/L
	1.91	2.23	3.81	4.46	7.17	8.37	9.54	9.54
Rated current [Arms]	1.5		2.8		5.1		7.1	3.8
Maximum current [Arms]	02AT	02AL	04AT	04AL	08AT	08AL	10AT/L	10DT/L
	4.7	5.8	8.8	11.2	16.1	19.5	22.0	11.9
Motor inertia [10 ⁻⁴ kg·m ²]	0.330(0.360)		0.640(0.680)		1.64(1.69)		2.26(2.41)	2.26(2.41)
Allowable shaft end load	Radial [N]	245		392		392		392
	Axial [N]	74		147		147		147
Brake specification	Rated voltage	24VDC		24VDC		24VDC		24VDC
	Holding torque [N·m]	≥1.5		≥3.2		≥3.2		≥3.2
Weight [kg]	0.9(1.0)		1.3(1.4)		2.3(2.9)		3.1(3.8)	3.1(3.8)

Note: The values in parentheses represent the values of motors with brakes.

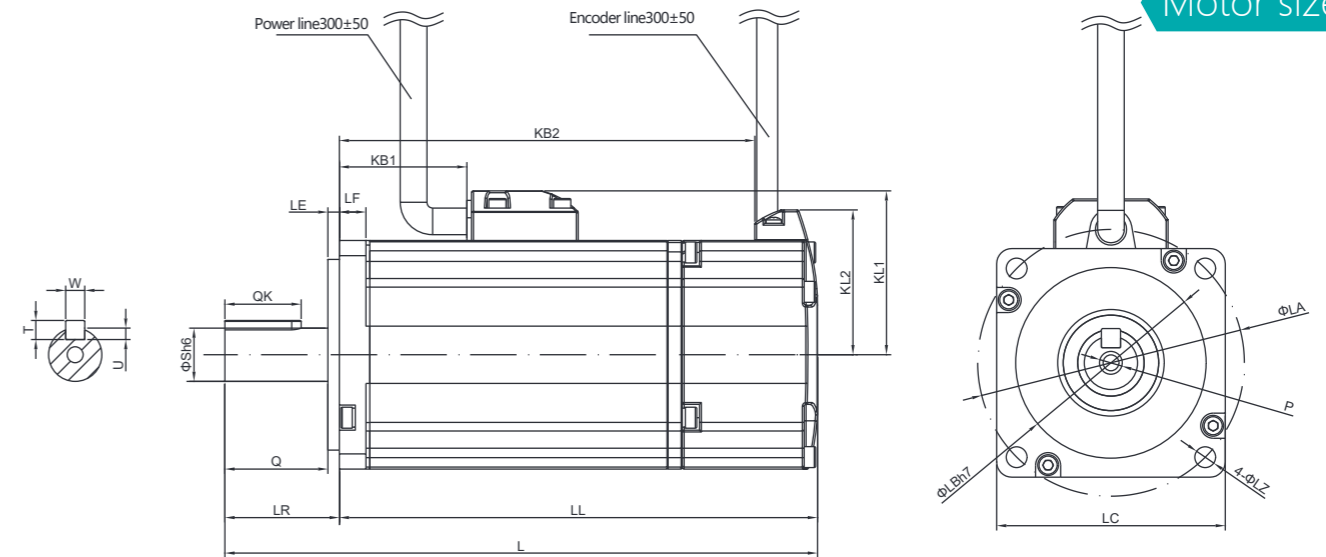

Power	EM3J-	L	LL	KB1	KB2	KL1	KL2	Flange Dimensions							S	P	key				
								LR	LE	LF	LC	LA	LB	LZ			QK	Q	W	T	U
200W	02AL	108(137)	78(107)	27.5(33.5)	61.5(90.5)	43	38	30	3	7	60	70	50	5.5	14	M5×12	20	27	5	5	3
200W	02AT	126.5(155.5)	96.5(125.5)	42.7(48.7)	80(109)	43	38	30	3	7	60	70	50	5.5	14	M5×12	20	27	5	5	3
400W	04AL	129(158)	99(128)	48.5(54.5)	82.5(111.5)	43	38	30	3	7	60	70	50	5.5	14	M5×12	20	27	5	5	3
400W	04AT	147.5(176.5)	117.5(146.5)	48.5(54.5)	101(130)	43	38	30	3	7	60	70	50	5.5	14	M5×12	20	27	5	5	3
750W	08AL	142(175)	102(135)	58.2(59.2)	35.8(67.8)	53	48	40	3	8	80	90	70	6.6	19	M6×12	25	37	6	6	3.5
750W	08AT	158.5(191.5)	118.5(151.5)	58.2(59.2)	52.3(84.3)	53	48	40	3	8	80	90	70	6.6	19	M6×12	25	37	6	6	3.5
1.0kW	10=L	157(190)	117(150)	72.2(73.2)	34.3(56.3)	53	48	40	3	8	80	90	70	6.6	19	M6×12	25	37	6	6	3.5
1.0kW	10=T	173.5(206.5)	133.5(166.5)	72.2(73.2)	34.3(56.3)	53	48	40	3	8	80	90	70	6.6	19	M6×12	25	37	6	6	3.5

Note: The values in parentheses represent the values of motors with brakes.

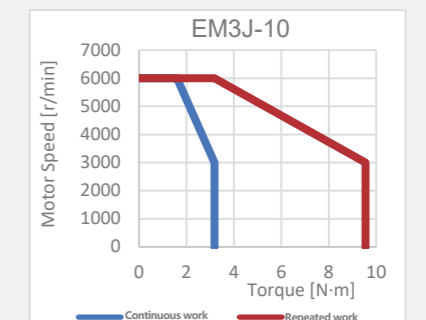
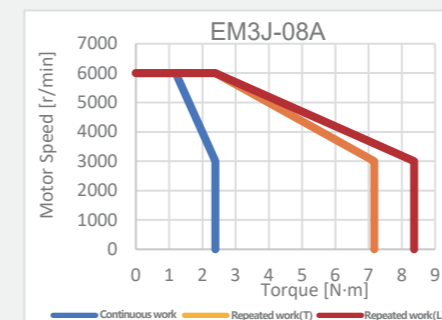
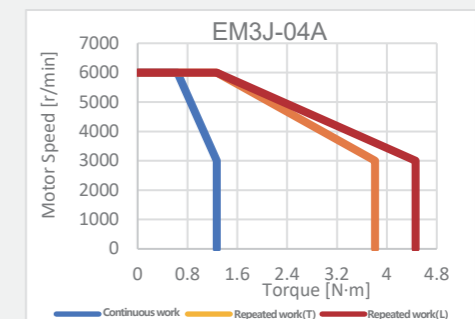
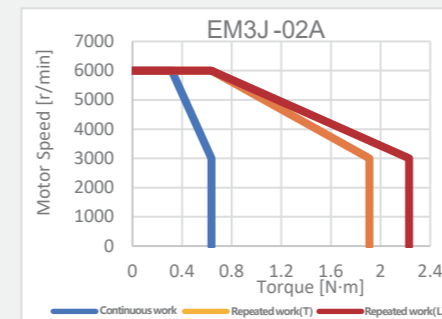

Note: T represents a 17-bits absolute
 L represents a 23-bits absolute

EM3G servo motor(0.85kW~7.5kW)

Medium capacity | Medium speed | Medium inertia

Motor size

EM3G- 13 A L A 2 2 4



Rated output power Voltage grade encoder Design order Shaft end Optional Plug type

09	0.85kW
13	1.3kW
18	1.8kW
29	2.9kW
44	4.4kW
55	5.5kW
75	7.5kW

A	200VAC
D	400VAC

T	17-bits absolute
L	23-bits absolute

A	-
---	---

2	Straight, with keys, Threaded
---	-------------------------------

1	No oil seals, No brakes
2	With oil seal, No brakes
3	No oil seals, With brake
4	With oil seal, With brake

4	Aviation Plug
---	---------------

Note: 1. Please refer to "Model Comparison Table" for details.
 2. Motor body heat resistance class: F
 3. Motor body protection mode: self-cooling, IP65/IP67

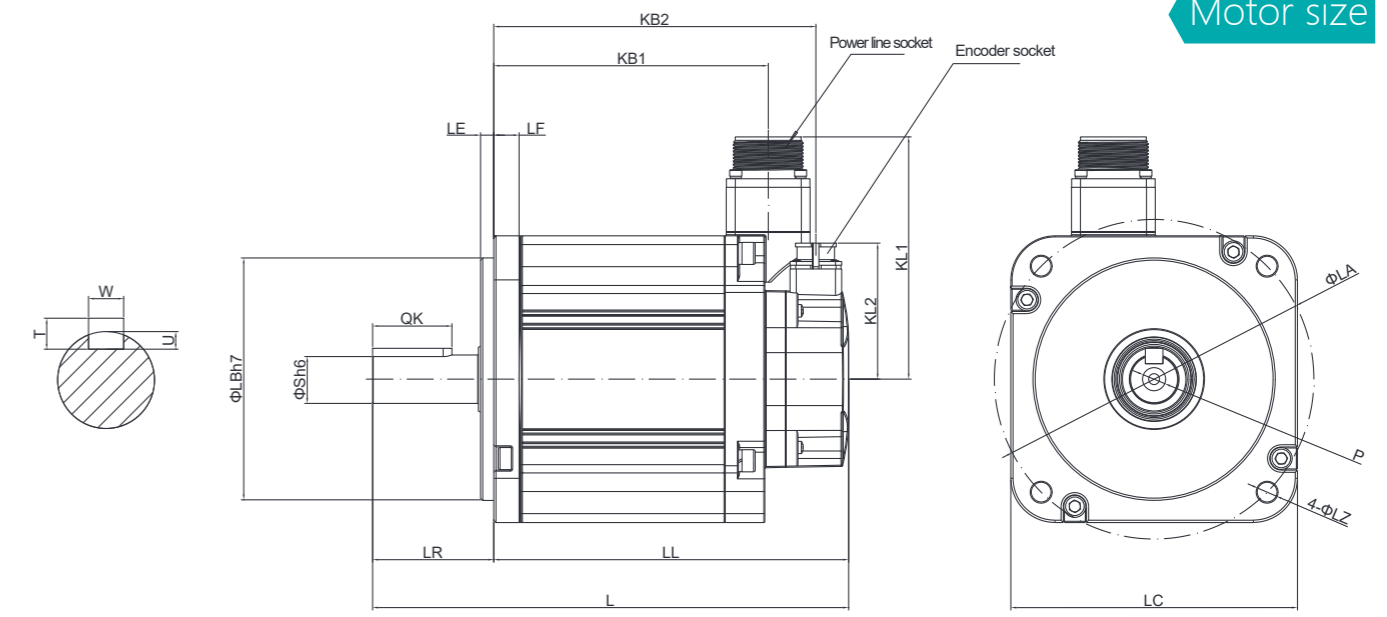

Power	EM3G-	L	LL	KB1	KB2	KL1	KL2	Flange Dimensions								S	P	key			
								LR	LE	LF	LC	LA	LB	LZ	QK			W	T	U	
0.85kW	09□	185(215)	131(161)	94.5	116(146)	112	58.5	55	6	12	130	145	110	9	22	M6×20	32	8	7	4	
1.3kW	13□	200(230)	146(176)	109.5	131(161)	112	58.5	55	6	12	130	145	110	9	22	M6×20	32	8	7	4	
1.8kW	18□	215(245)	161(191)	124.5	146(176)	112	58.5	55	6	12	130	145	110	9	22	M6×20	32	8	7	4	
2.9kW	29D	239(284)	160(205)	135.5(139.8)	145.5(190.2)	142	62	79	3.2	18	180	200	114.3	13.5	35	M12×25	65	10	8	5	
4.4kW	44D	258(303)	179(224)	154.5(158.8)	164.5(209.2)	142	62	79	3.2	18	180	200	114.3	13.5	35	M12×25	65	10	8	5	
5.5kW	55D	324(377)	221(264)	186.5(198.8)	196.5(249.2)	142	62	113	3.2	18	180	200	114.3	13.5	42	M16×32	96	12	10	5	
7.5kW	75D	360(413)	247(300)	222.5(234.8)	232.5(285.2)	142	62	113	3.2	18	180	200	114.3	13.5	42	M16×32	96	12	10	5	

Note: The values in parentheses represent the values of motors with brakes.

		200VAC			400VAC						
		09A	13A	18A	09D	13D	18D	29D	44D	55D	75D
EM3G-											
Flange [mm]		130	130	130	130	130	130	180	180	180	180
Rated power [kW]		0.85	1.3	1.8	0.85	1.3	1.8	2.9	4.4	5.5	7.5
Rated speed [r/min]		1500	1500	1500	1500	1500	1500	1500	1500	1500	1500
Maximum speed [r/min]		3000	3000	3000	3000	3000	3000	3000	3000	3000	3000
Rated torque [N·m]		5.41	8.28	11.5	5.41	8.28	11.5	18.6	28.4	35.0	48.0
Maximum torque [N·m]		16.2	24.8	31.0	16.2	24.8	31.0	55.8	80.0	105	120
Rated current [Arms]		6.8	9.7	14.5	3.4	5.0	7.1	11.5	16.8	20.3	26.5
Maximum current [Arms]		22.6	29.7	42.0	10.9	15.6	21.2	37.0	49.5	64.0	70.0
Motor inertia [10 ⁻⁴ kg·m ²]		11.9(12.5)	17.3(17.9)	22.3(22.9)	11.9(12.5)	17.3(17.9)	22.3(22.9)	43.4(49.2)	58.8(64.6)	85.5(91.5)	117(123)
Allowable shaft end load	Radial[N]	490	686	980	490	686	980	1470	1470	1764	1764
	Axial[N]	98	343	392	98	343	392	490	490	588	588
Brake specification	Rated voltage	24VDC	24VDC	24VDC	24VDC	24VDC	24VDC	24VDC	24VDC	24VDC	24VDC
	Holding torque[N·m]	≥20	≥20	≥20	≥20	≥20	≥20	≥44	≥44	≥72	≥72
Weight[kg]		5.6(7.3)	7.0(8.7)	8.3(10.0)	5.6(7.3)	7.0(8.7)	8.3(10.0)	14.6(18.8)	17.6(21.8)	23.2(27.8)	29.0(33.6)

Note: The values in parentheses represent the values of motors with brakes.

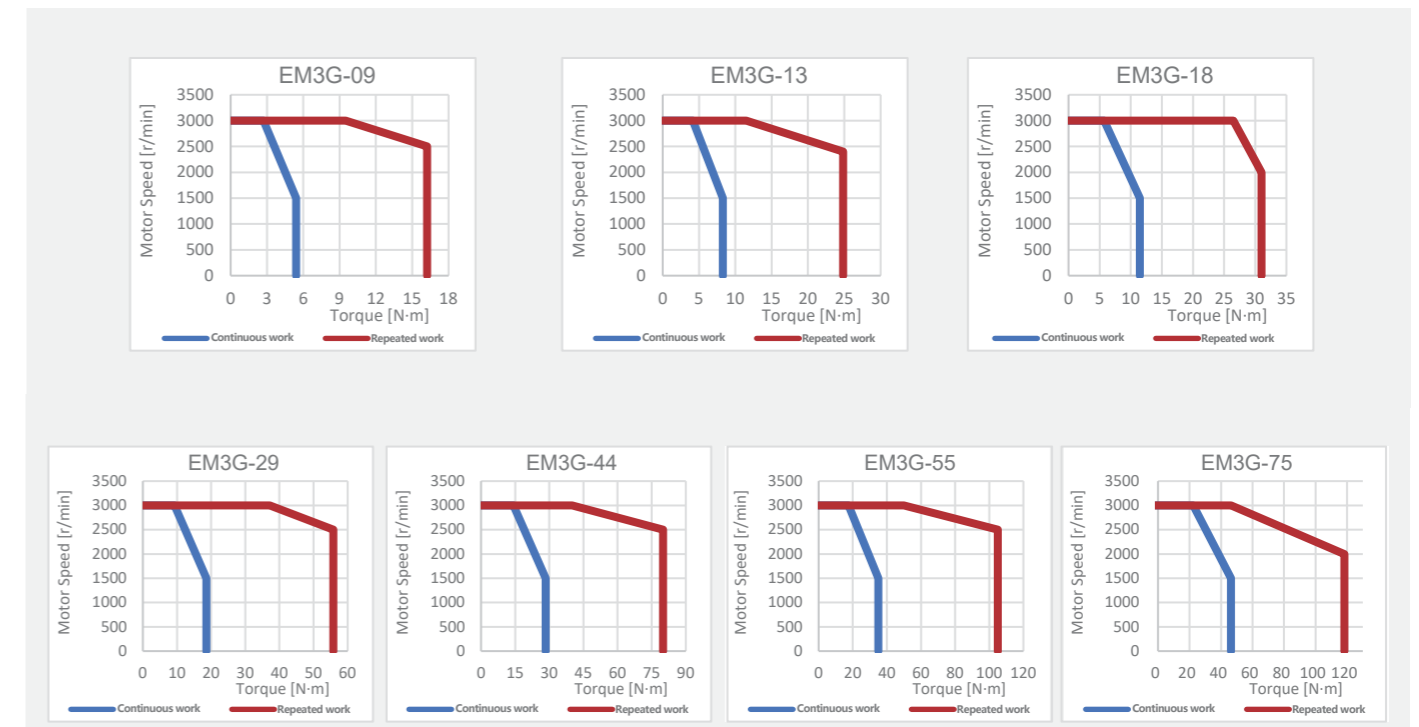

Note: T represents a 17-bits absolute
 L represents a 23-bits absolute

02 Model comparison table

EM3A | Low inertia | 3000 r/min

Power	Motor model	Brake	Connector	Flange	Trunnion	Drive	Input power	Power cable	Encoder cable				
50W	EM3A-A5ALA221	-	Standard wire	40mm	Φ8	ED3L-A5A	Single phase AC 200V~240V	EC3P-N9118-□□	EC3S-A1124-□□ (Including battery)				
	EM3A-A5ALA241	●						EC3P-B9118-□□	EC3S-I1124-□□ (No battery)				
	EM3A-A5ALA222	-	Waterproof wire					EC3P-N9718-□□	EC3S-A1724-□□ (Including battery)				
	EM3A-A5ALA242	●						EC3P-B9718-□□	EC3S-I1724-□□ (No battery)				
100W	EM3A-01ATA221	-	Standard wire					40mm	Φ8	ED3L-01A	Single phase AC 200V~240V	EC3P-N9118-□□	EC3S-A1124-□□ (Including battery)
	EM3A-01ATA241	●										EC3P-B9118-□□	EC3S-I1124-□□ (No battery)
	EM3A-01ATA222	-	Waterproof wire									EC3P-N9718-□□	EC3S-A1724-□□ (Including battery)
	EM3A-01ATA242	●										EC3P-B9718-□□	EC3S-I1724-□□ (No battery)
	EM3A-01ALA221	-	Standard wire	EC3P-N9118-□□	EC3S-A1124-□□ (Including battery)								
	EM3A-01ALA241	●		EC3P-B9118-□□	EC3S-I1124-□□ (No battery)								
EM3A-01ALA222	-	Waterproof wire	EC3P-N9718-□□	EC3S-A1724-□□ (Including battery)									
EM3A-01ALA242	●		EC3P-B9718-□□	EC3S-I1724-□□ (No battery)									
200W	EM3A-02ATA221	-	Standard wire	60mm	Φ14	ED3L-02A	Single phase AC 200V~240V	EC3P-N9118-□□	EC3S-A1124-□□ (Including battery)				
	EM3A-02ATA241	●						EC3P-B9118-□□	EC3S-I1124-□□ (No battery)				
	EM3A-02ATA222	-	Waterproof wire					EC3P-N9718-□□	EC3S-A1724-□□ (Including battery)				
	EM3A-02ATA242	●						EC3P-B9718-□□	EC3S-I1724-□□ (No battery)				
	EM3A-02ALA221	-	Standard wire					EC3P-N9118-□□	EC3S-A1124-□□ (Including battery)				
	EM3A-02ALA241	●						EC3P-B9118-□□	EC3S-I1124-□□ (No battery)				
EM3A-02ALA222	-	Waterproof wire	EC3P-N9718-□□					EC3S-A1724-□□ (Including battery)					
EM3A-02ALA242	●		EC3P-B9718-□□					EC3S-I1724-□□ (No battery)					
400W	EM3A-04ATA221	-	Standard wire	60mm	Φ14	ED3L-04A	Single phase AC 200V~240V	EC3P-N9118-□□	EC3S-A1124-□□ (Including battery)				
	EM3A-04ATA241	●						EC3P-B9118-□□	EC3S-I1124-□□ (No battery)				
	EM3A-04ATA222	-	Waterproof wire					EC3P-N9718-□□	EC3S-A1724-□□ (Including battery)				
	EM3A-04ATA242	●						EC3P-B9718-□□	EC3S-I1724-□□ (No battery)				
	EM3A-04ALA221	-	Standard wire					EC3P-N9118-□□	EC3S-A1124-□□ (Including battery)				
	EM3A-04ALA241	●						EC3P-B9118-□□	EC3S-I1124-□□ (No battery)				
EM3A-04ALA222	-	Waterproof wire	EC3P-N9718-□□					EC3S-A1724-□□ (Including battery)					
EM3A-04ALA242	●		EC3P-B9718-□□					EC3S-I1724-□□ (No battery)					

Power	Motor model	Brake	Connector	Flange	Trunnion	Drive	Input power	Power cable	Encoder cable					
750W	EM3A-08ATA221	-	Standard wire	80mm	Φ19	ED3L-08A	Single phase / three phase AC 200V~240V	EC3P-N8118-□□	EC3S-A1124-□□ (Including battery)					
	EM3A-08ATA241	●						EC3P-B8118-□□	EC3S-I1124-□□ (No battery)					
	EM3A-08ATA222	-	Waterproof wire					EC3P-N8718-□□	EC3S-A1724-□□ (Including battery)					
	EM3A-08ATA242	●						EC3P-B8718-□□	EC3S-I1724-□□ (No battery)					
	EM3A-08ALA221	-	Standard wire					EC3P-N8118-□□	EC3S-A1124-□□ (Including battery)					
	EM3A-08ALA241	●						EC3P-B8118-□□	EC3S-I1124-□□ (No battery)					
	EM3A-08ALA222	-	Waterproof wire					EC3P-N8718-□□	EC3S-A1724-□□ (Including battery)					
	EM3A-08ALA242	●						EC3P-B8718-□□	EC3S-I1724-□□ (No battery)					
1.0kW	EM3A-10ATA221	-	Standard wire	80mm	Φ19	ED3L-10A	Single phase / three phase AC 200V~240V	EC3P-N8118-□□	EC3S-A1124-□□ (Including battery)					
	EM3A-10ATA241	●						EC3P-B8118-□□	EC3S-I1124-□□ (No battery)					
	EM3A-10ATA222	-	Waterproof wire					EC3P-N8718-□□	EC3S-A1724-□□ (Including battery)					
	EM3A-10ATA242	●						EC3P-B8718-□□	EC3S-I1724-□□ (No battery)					
	EM3A-10ALA221	-	Standard wire					EC3P-N8118-□□	EC3S-A1124-□□ (Including battery)					
	EM3A-10ALA241	●						EC3P-B8118-□□	EC3S-I1124-□□ (No battery)					
EM3A-10ALA222	-	Waterproof wire	EC3P-N8718-□□	EC3S-A1724-□□ (Including battery)										
EM3A-10ALA242	●		EC3P-B8718-□□	EC3S-I1724-□□ (No battery)										
1.5kW	EM3A-15ATB224	-	Aviation Plug	100mm	Φ24	ED3L-15A	Single phase / three phase AC 200V~240V	EC3P-N9314-□□	EC3S-A1924-□□ (Including battery)					
	EM3A-15ATB244	●						EC3P-B9314-□□						
	EM3A-15ALB224	-						EC3P-N9314-□□						
	EM3A-15ALB244	●						EC3P-B9314-□□						
	EM3A-15DTB224	-						Aviation Plug		100mm	Φ24	ED3L-15D	three phase AC 380V~440V	EC3P-N9314-□□
	EM3A-15DTB244	●												EC3P-B9314-□□
EM3A-15DLB224	-	Aviation Plug	100mm	Φ24	ED3L-15D	three phase AC 380V~440V	EC3P-N9314-□□							
EM3A-15DLB244	●						EC3P-B9314-□□							
2.0kW	EM3A-20ATB224	-	Aviation Plug	100mm	Φ24	ED3L-20A	three phase AC 200V~240V	EC3P-N9314-□□	EC3S-A1924-□□ (Including battery)					
	EM3A-20ATB244	●						EC3P-B9314-□□						
	EM3A-20ALB224	-						EC3P-N9314-□□						
	EM3A-20ALB244	●						EC3P-B9314-□□						
	EM3A-20DTB224	-						Aviation Plug		100mm	Φ24	ED3L-20D	three phase AC 380V~440V	EC3P-N9314-□□
	EM3A-20DTB244	●												EC3P-B9314-□□
EM3A-20DLB224	-	Aviation Plug	100mm	Φ24	ED3L-20D	three phase AC 380V~440V	EC3P-N9314-□□							
EM3A-20DLB244	●						EC3P-B9314-□□							
3.0kW	*EM3A-30DTA224	-	Aviation Plug	130mm	Φ28	ED3L-30D	three phase AC 380V~440V	EC3P-N9314-□□	EC3S-A1924-□□ (Including battery)					
	*EM3A-30DTA244	●						EC3P-B9314-□□						
	EM3A-30DLA224	-						EC3P-N9314-□□						
	EM3A-30DLA244	●						EC3P-B9314-□□						
4.0kW	*EM3A-40DTA224	-	Aviation Plug	130mm	Φ28	ED3L-50D	three phase AC 380V~440V	EC3P-N9319-□□	EC3S-A1924-□□ (Including battery)					
	*EM3A-40DTA244	●						EC3P-B9319-□□						
	EM3A-40DLA224	-						EC3P-N9319-□□						
	EM3A-40DLA244	●						EC3P-B9319-□□						
5.0kW	*EM3A-50DTA224	-	Aviation Plug	130mm	Φ28	ED3L-50D	three phase AC 380V~440V	EC3P-N9319-□□	EC3S-A1924-□□ (Including battery)					
	*EM3A-50DTA244	●						EC3P-B9319-□□						
	EM3A-50DLA224	-						EC3P-N9319-□□						
	EM3A-50DLA244	●						EC3P-B9319-□□						

EM3G | Medium inertia| 1500 r/min

Power	Motor model	Brake	Connector	Flange	Trunnion	Drive	Input power	Power cable	Encoder cable	
850W	EM3G-09ATA224	-	Aviation Plug	130mm	Φ22	ED3L-10A	Single phase / three phase AC 200V~240V	EC3P-N9314-□□	EC3S-A1924-□□ (Including battery)	
	EM3G-09ATA244	●						EC3P-B9314-□□		
	EM3G-09ALA224	-	Aviation Plug					EC3P-N9314-□□		
	EM3G-09ALA244	●						EC3P-B9314-□□		
	EM3G-09DTA224	-	Aviation Plug			ED3L-10D	three phase AC 380V~440V	EC3P-N9314-□□		EC3S-I1924-□□ (No battery)
	EM3G-09DTA244	●						EC3P-B9314-□□		
	EM3G-09DLA224	-						EC3P-N9314-□□		
	EM3G-09DLA244	●						EC3P-B9314-□□		
1.3kW	EM3G-13ATA224	-	Aviation Plug	130mm	Φ22	ED3L-15A	Single phase / three phase AC 200V~240V	EC3P-N9314-□□	EC3S-A1924-□□ (Including battery)	
	EM3G-13ATA244	●						EC3P-B9314-□□		
	EM3G-13ALA224	-	Aviation Plug					EC3P-N9314-□□		
	EM3G-13ALA244	●						EC3P-B9314-□□		
	EM3G-13DTA224	-	Aviation Plug			ED3L-15D	three phase AC 380V~440V	EC3P-N9314-□□		EC3S-I1924-□□ (No battery)
	EM3G-13DTA244	●						EC3P-B9314-□□		
	EM3G-13DLA224	-						EC3P-N9314-□□		
	EM3G-13DLA244	●						EC3P-B9314-□□		
1.8kW	EM3G-18ATA224	-	Aviation Plug	130mm	Φ22	ED3L-20D	Single phase / three phase AC 380V~440V	EC3P-N9314-□□	EC3S-A1924-□□ (Including battery)	
	EM3G-18ATA244	●						EC3P-B9314-□□		
	EM3G-18ALA224	-	Aviation Plug					EC3P-N9314-□□		
	EM3G-18ALA244	●						EC3P-B9314-□□		
	EM3G-18DTA224	-	Aviation Plug			ED3L-20D	three phase AC 380V~440V	EC3P-N9314-□□		EC3S-I1924-□□ (No battery)
	EM3G-18DTA244	●						EC3P-B9314-□□		
	EM3G-18DLA224	-						EC3P-N9314-□□		
	EM3G-18DLA244	●						EC3P-B9314-□□		
2.9kW	*EM3G-29DTA224	-	Aviation Plug	180mm	Φ35	ED3L-30D	three phase AC 380V~440V	EC3P-N8214-□□	EC3S-A1924-□□ (Including battery)	
	*EM3G-29DTA244	●						EC3P-B8214-□□		
	EM3G-29DLA224	-						EC3P-N8214-□□		EC3S-I1924-□□ (No battery)
	EM3G-29DLA244	●						EC3P-B8214-□□		
4.4kW	*EM3G-44DTA224	-	Aviation Plug	180mm	Φ35	ED3L-50D	three phase AC 380V~440V	EC3P-N9212-□□	EC3S-A1924-□□ (Including battery)	
	*EM3G-44DTA244	●						EC3P-B9212-□□		
	EM3G-44DLA224	-						EC3P-N9212-□□		EC3S-I1924-□□ (No battery)
	EM3G-44DLA244	●						EC3P-B9212-□□		
5.5kW	*EM3G-55DTA224	-	Aviation Plug	180mm	Φ42	ED3L-75D	three phase AC 380V~440V	EC3P-N9212-□□	EC3S-A1924-□□ (Including battery)	
	*EM3G-55DTA244	●						EC3P-B9212-□□		
	EM3G-55DLA224	-						EC3P-N9212-□□		EC3S-I1924-□□ (No battery)
	EM3G-55DLA244	●						EC3P-B9212-□□		
7.5kW	*EM3G-75DTA224	-	Aviation Plug	180mm	Φ42	ED3L-75D	three phase AC 380V~440V	EC3P-N9211-□□	EC3S-A1924-□□ (Including battery)	
	*EM3G-75DTA244	●						EC3P-B9211-□□		
	EM3G-75DLA224	-						EC3P-N9211-□□		EC3S-I1924-□□ (No battery)
	EM3G-75DLA244	●						EC3P-B9211-□□		

EM3J | Medium inertia | 3000 r/min

Power	Motor model	Brake	Connector	Flange	Trunnion	Drive	Input power	Power cable	Encoder cable		
200W	EM3J-02ATA221	-	Standard wire	60mm	Φ14	ED3L-02A	Single phase 200V~240V	EC3P-N9118-□□	EC3S-A1124-□□ (Including battery)		
	EM3J-02ATA241	●						EC3P-B9118-□□	EC3S-I1124-□□ (No battery)		
	EM3J-02ATA222	-	Waterproof wire					EC3P-N9718-□□	EC3S-A1724-□□ (Including battery)		
	EM3J-02ATA242	●						EC3P-B9718-□□	EC3S-I1724-□□ (No battery)		
	EM3J-02ALA221	-	Standard wire			ED3L-02A	Single phase 200V~240V	EC3P-N9118-□□	EC3S-A1124-□□ (Including battery)		
	EM3J-02ALA241	●						EC3P-B9118-□□	EC3S-I1124-□□ (No battery)		
	EM3J-02ALA222	-						Waterproof wire	EC3P-N9718-□□	EC3S-A1724-□□ (Including battery)	
	EM3J-02ALA242	●							EC3P-B9718-□□	EC3S-I1724-□□ (No battery)	
400W	EM3J-04ATA221	-	Standard wire	60mm	Φ14	ED3L-04A	Single phase / three phase AC 200V~240V	EC3P-N9118-□□	EC3S-A1124-□□ (Including battery)		
	EM3J-04ATA241	●						EC3P-B9118-□□	EC3S-I1124-□□ (No battery)		
	EM3J-04ATA222	-	Waterproof wire					EC3P-N9718-□□	EC3S-A1724-□□ (Including battery)		
	EM3J-04ATA242	●						EC3P-B9718-□□	EC3S-I1724-□□ (No battery)		
	EM3J-04ALA221	-	Standard wire			ED3L-04A	Single phase / three phase AC 200V~240V	EC3P-N9118-□□	EC3S-A1124-□□ (Including battery)		
	EM3J-04ALA241	●						EC3P-B9118-□□	EC3S-I1124-□□ (No battery)		
	EM3J-04ALA222	-						Waterproof wire	EC3P-N9718-□□	EC3S-A1724-□□ (Including battery)	
	EM3J-04ALA242	●							EC3P-B9718-□□	EC3S-I1724-□□ (No battery)	
750W	EM3J-08ATA221	-	Standard wire	80mm	Φ19	ED3L-08A	Single phase / three phase AC 200V~240V	EC3P-N8118-□□	EC3S-A1124-□□ (Including battery)		
	EM3J-08ATA241	●						EC3P-B8118-□□	EC3S-I1124-□□ (No battery)		
	EM3J-08ATA222	-	Waterproof wire					EC3P-N8718-□□	EC3S-A1724-□□ (Including battery)		
	EM3J-08ATA242	●						EC3P-B8718-□□	EC3S-I1724-□□ (No battery)		
	EM3J-08ALA221	-	Standard wire			ED3L-08A	Single phase / three phase AC 200V~240V	EC3P-N8118-□□	EC3S-A1124-□□ (Including battery)		
	EM3J-08ALA241	●						EC3P-B8118-□□	EC3S-I1124-□□ (No battery)		
	EM3J-08ALA222	-						Waterproof wire	EC3P-N8718-□□	EC3S-A1724-□□ (Including battery)	
	EM3J-08ALA242	●							EC3P-B8718-□□	EC3S-I1724-□□ (No battery)	
1.0kW	EM3J-10ATA221	-	Standard wire	80mm	Φ19	ED3L-10A	Single phase / three phase AC 200V~240V	EC3P-N8118-□□	EC3S-A1124-□□ (Including battery)		
	EM3J-10ATA241	●						EC3P-B8118-□□	EC3S-I1124-□□ (No battery)		
	EM3J-10ALA221	-	Standard wire					ED3L-10D	three phase AC 380V~440V	EC3P-N8118-□□	EC3S-A1124-□□ (Including battery)
	EM3J-10ALA241	●								EC3P-B8118-□□	EC3S-I1124-□□ (No battery)
	EM3J-10DTA221	-	Standard wire			EC3P-N8118-□□	EC3S-A1124-□□ (Including battery)				
	EM3J-10DTA241	●				EC3P-B8118-□□	EC3S-I1124-□□ (No battery)				
	EM3J-10DLA221	-	Standard wire			ED3L-10D	three phase AC 380V~440V	EC3P-N8118-□□	EC3S-A1124-□□ (Including battery)		
	EM3J-10DLA241	●						EC3P-B8118-□□	EC3S-I1124-□□ (No battery)		

- Note:
1. "-" Represents a model without brakes, ● Indicates a model with brakes.
 2. Models with "*" are under development, please look forward to it.
 3. Encoder cable with battery is selected by default, If there is no absolute demand, You can select the battery free cable model.
 4. □□ in the cable model indicates the length. Standard length: 1M5(1.5m), 03(3m), 05(5m), 08(8m), 10(10m), 12(12m), 15(15m), 20(20m). Flexible cables are optional, marked with -Rx. For example, the model of ec3P-N9118-03 flexible cable is EC3P-N9118-RX-03. Optional shielded cable, unmarked with "-SS".
Example: EC3P-N9118-03 Shielded cable model: EC3P-N9118-SS-03.
 5. The selection of I / O plug is determined by the driver: EtherCAT / PN driver product: 26 pin plug (sm-26J). Pulse driver products :50-pin plug (SM-50J).
 6. Optional debugging cable model: USB communication cable MINI USB- double magnetic ring shielding -1M5.
 7. Optional communication cable model: DK-HHSB-RJ-XX.

03 Accessories

Encoder cable

EC3S-I1124-□□ (Incremental)

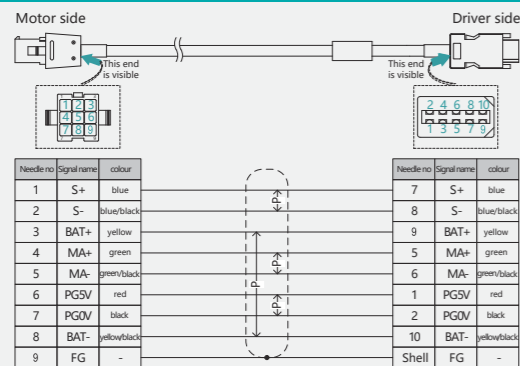

EC3S-I1124 - □□ (Absolute value)

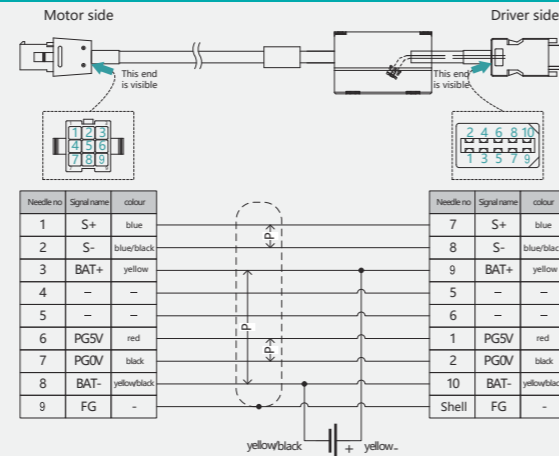

EC3S-I1724-□□ (Incremental, IP67 plug)

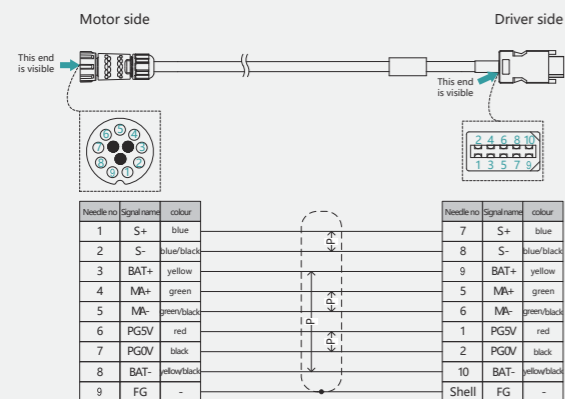

EC3S-A1724-□□ (Absolute value, IP67 plug)

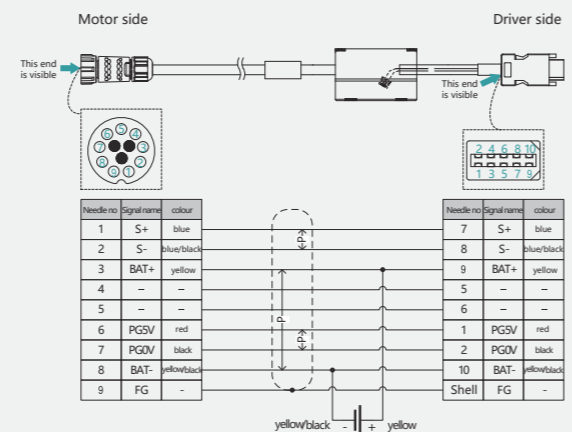

EC3S-I1924-□□ (Incremental, IP67 plug)

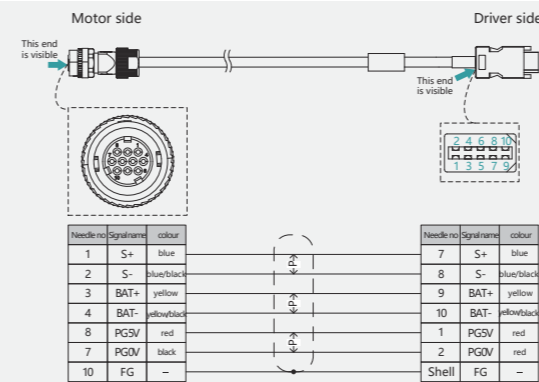

EC3S-A1924-□□ (Absolute value, IP67 plug)

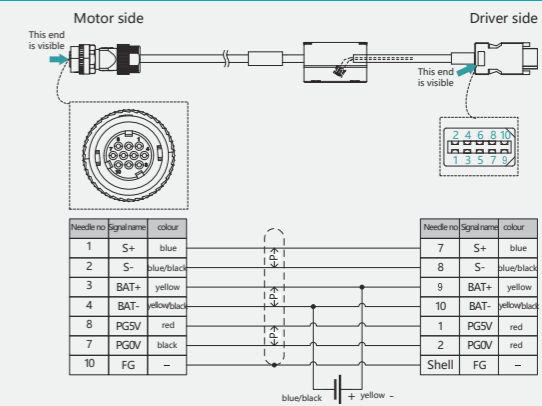

Power cable

EC3P-N9118-□□ (No brake)

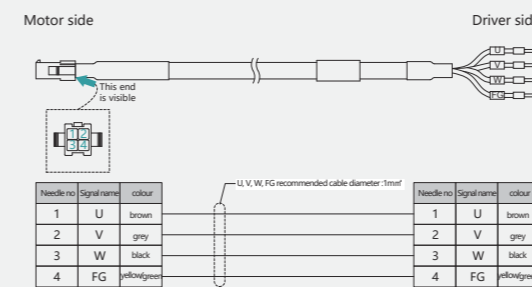

EC3P-B9118-□□ (With brake)

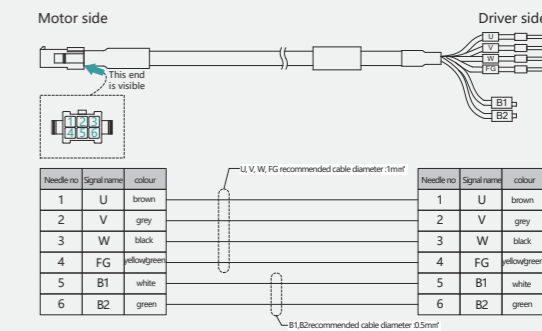

EC3P-N9718-□□ (No brake, IP67 plug)

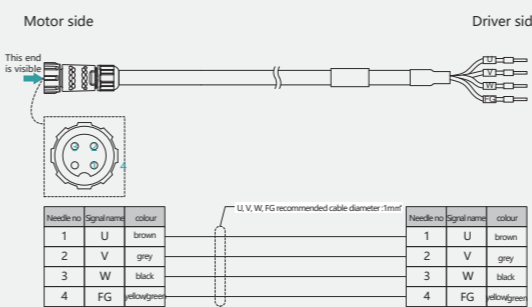

EC3P-B9718-□□ (With brake, IP67 plug)

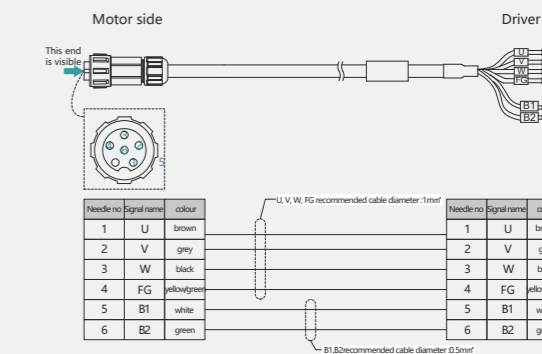

EC3P-N8118-□□ (No brake)

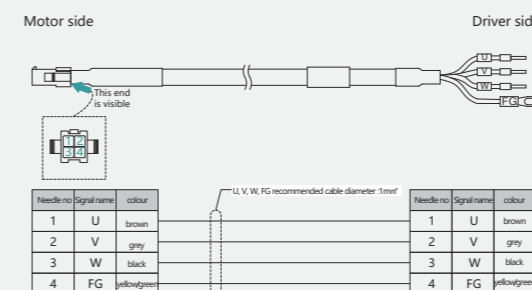

EC3P-B8118-□□ (With brake)

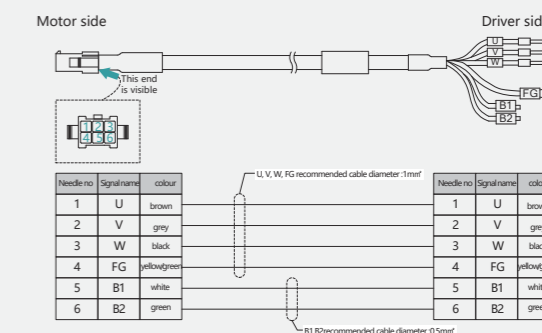

Power cable

EC3P-N8718-□□ (No brake, IP67 plug)

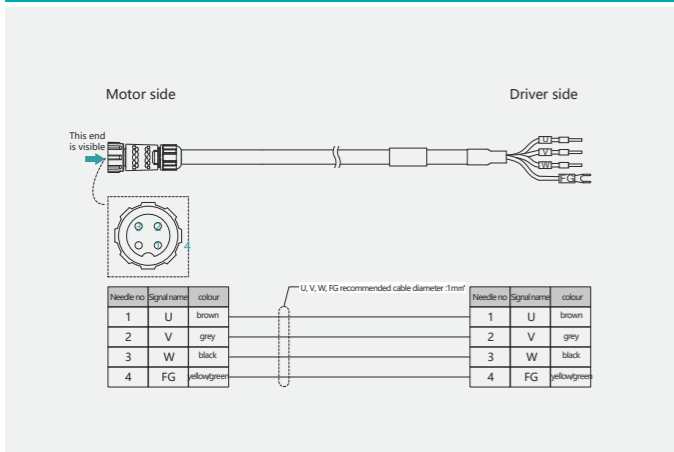

EC3P-B8718-□□ (With brake, IP67 plug)

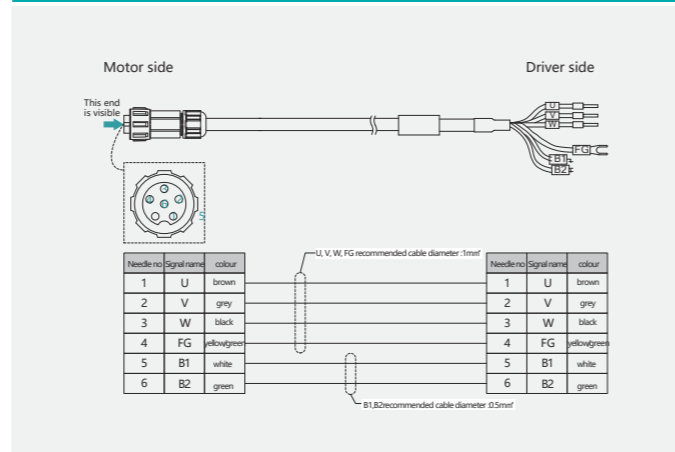

Power cable

EC3P-N8214-□□ (No brake, IP67 plug)

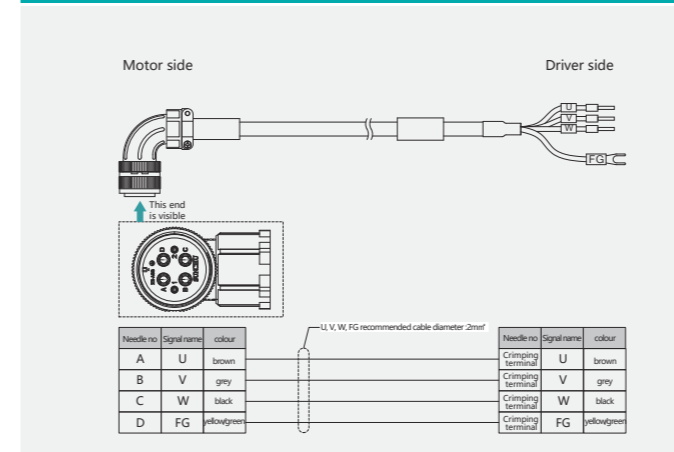

EC3P-B8214-□□ (With brake, IP67 plug)

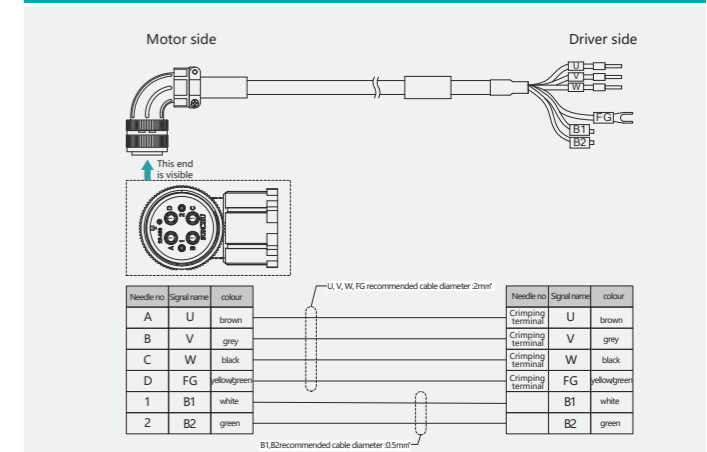

EC3P-N9314-□□ (No brake, IP67 plug)

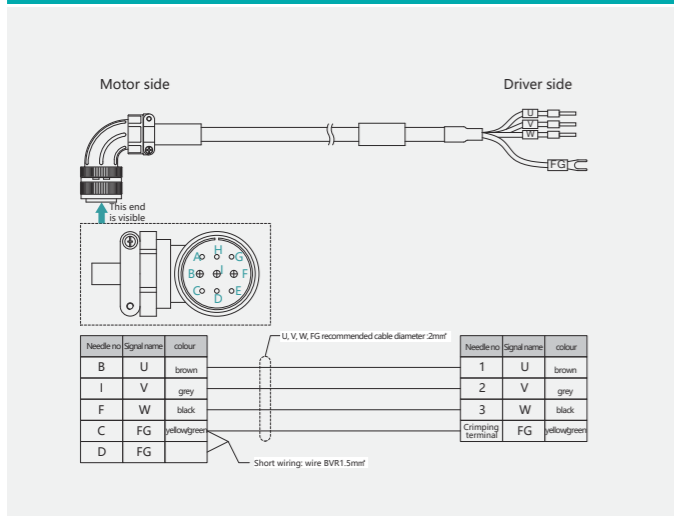

EC3P-B9314-□□ (With brake, IP67 plug)

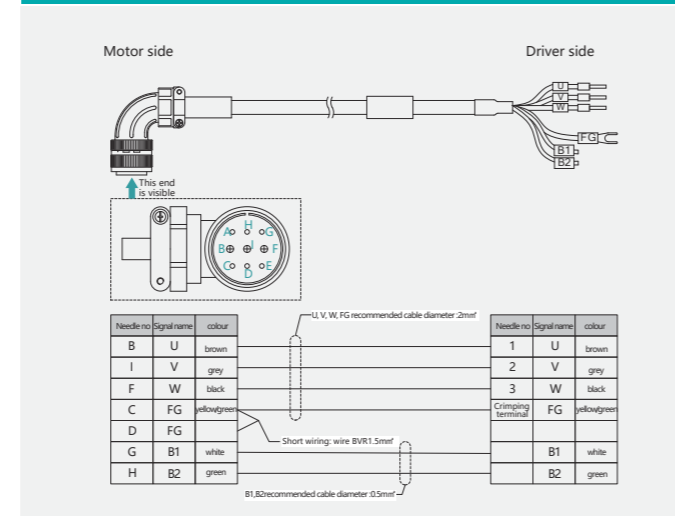

EC3P-N9212-□□ (No brake, IP67 plug)

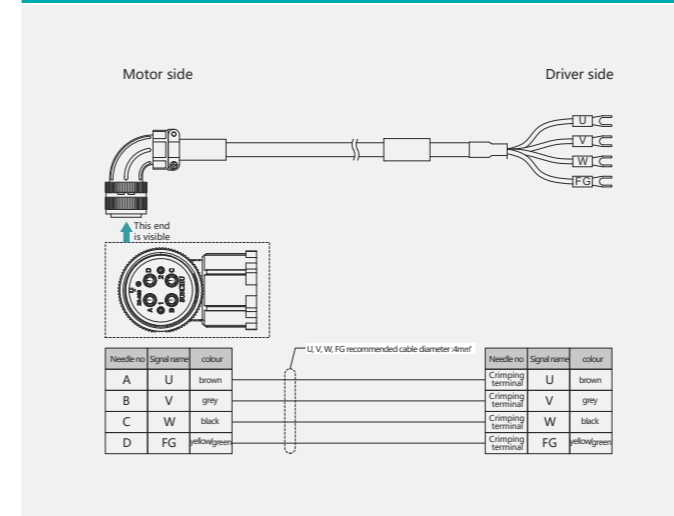

EC3P-B9212-□□ (With brake, IP67 plug)

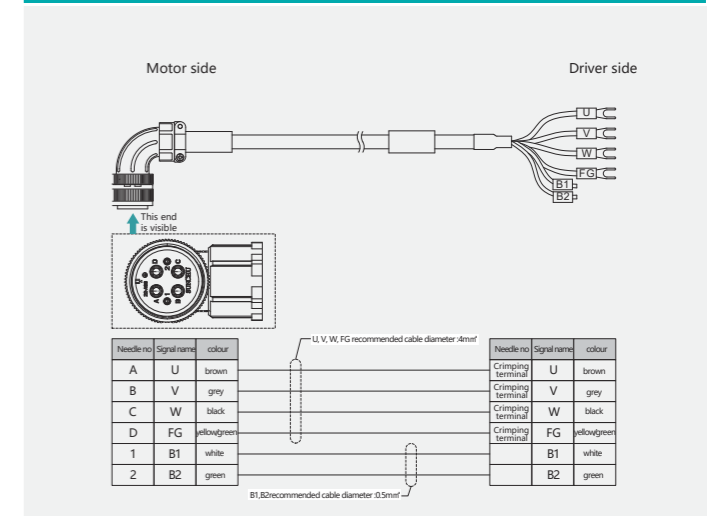

EC3P-N9319-□□ (No brake, IP67 plug)

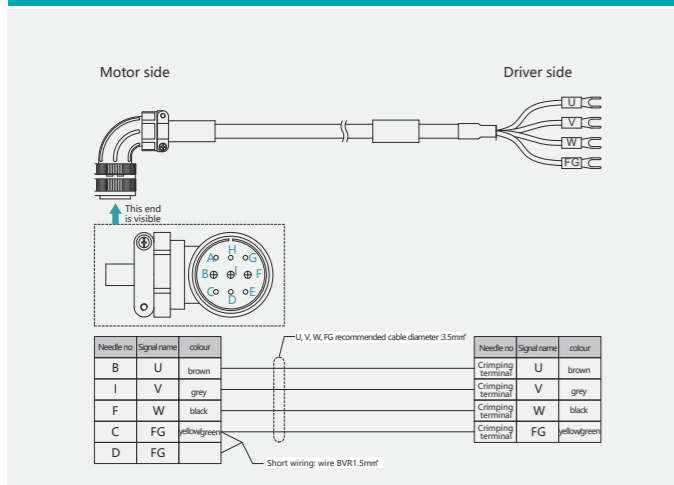

EC3P-B9319-□□ (With brake, IP67 plug)

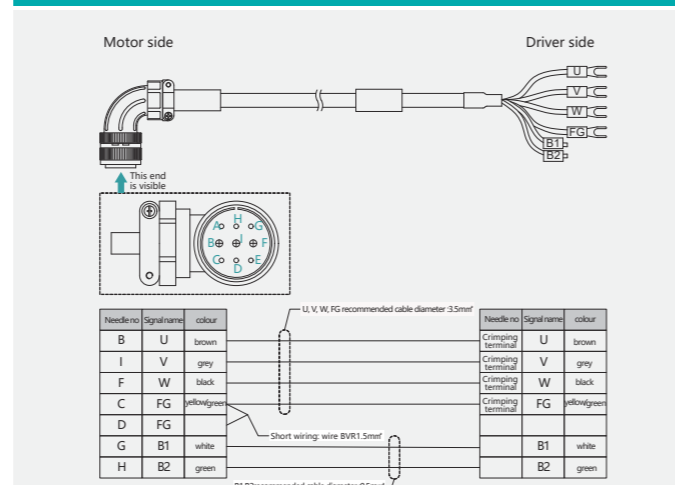

EC3P-N9211-□□ (No brake, IP65 plug)

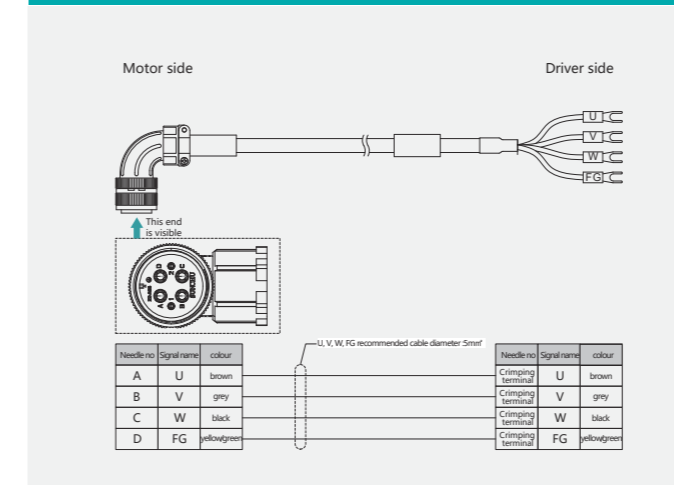



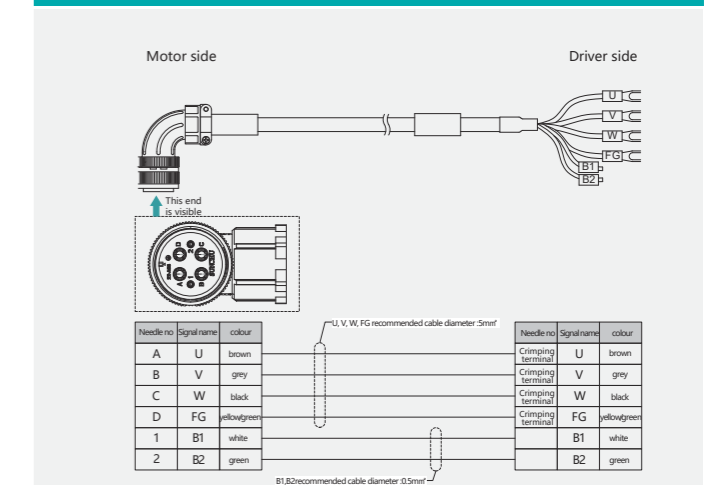

EC3P-B9211-□□ (With brake, IP65 plug)

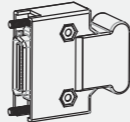
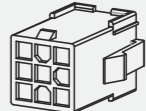
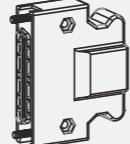
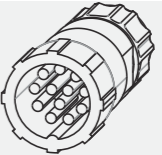
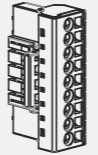
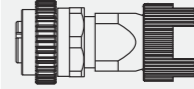
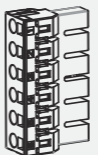
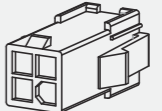
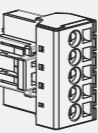

Peripheral specifications

Driver	Main circuit voltage	Built-in regenerative resistor specification	Minimum external regenerative resistance	Minimum current of circuit breaker
ED3L-A5A	Single phase AC 200V~240V	-	45Ω	4A (Single phase)
ED3L-01A	Single phase AC 200V~240V	-	45Ω	4A (Single phase)
ED3L-02A	Single phase AC 200V~240V	-	45Ω	4A (Single phase)
ED3L-04A	Single phase AC 200V~240V	-	45Ω	4A (Single phase)
ED3L-08A	Single phase/three phase AC 200V~240V	50Ω / 60W	25Ω	10A (Single phase) / 6A (three phase)
ED3L-10A	Single phase/three phase AC 200V~240V	50Ω / 60W	25Ω	16A (Single phase) / 6A (three phase)
ED3L-15A	Single phase/three phase AC 200V~240V	40Ω / 80W	25Ω	20A (Single phase) / 16A (three phase)
ED3L-20A	three phase AC 200V~240V	40Ω / 80W	25Ω	16A (three phase)
ED3L-10D	three phase AC 380V~440V	100Ω / 80W	65Ω	4A (three phase)
ED3L-15D	three phase AC 380V~440V	100Ω / 80W	65Ω	6A (three phase)
ED3L-20D	three phase AC 380V~440V	50Ω / 80W	40Ω	10A (three phase)
ED3L-30D	three phase AC 380V~440V	50Ω / 80W	40Ω	16A (three phase)
ED3L-50D	three phase AC 380V~440V	35Ω / 80W	20Ω	20A (three phase)
ED3L-75D	three phase AC 380V~440V	35Ω / 80W	20Ω	25A (three phase)

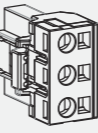
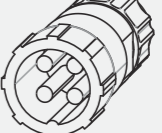
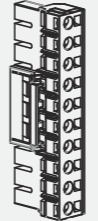
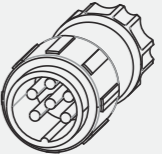
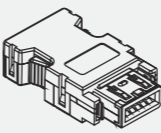
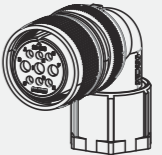
Other accessories

Drive side			Motor side		
Name	Illustration	Involving	Name	Illustration	Involving
IO plug SM-26J		ED3L bus driver (EtherCAT or Profinet)	Encoder plug (Standard wire)		EM3A motor (0.05kW ~ 1kW) EM3J motor EC3S-I1124-XX EC3S-A1124-XX
IO plug SM-50J		ED3L pulse driver	Encoder plug (Waterproof wire)		EM3A motor (0.05kW ~ 1kW) EM3J motor EC3S-I1724-XX EC3S-A1724-XX
Main circuit terminal Straight type, 9 pin, 10A		ED3L driver (200VAC, 0.05kW ~ 0.4kW)	Encoder plug (Straight type, 10pin, 3A)		EM3A motor (1.5kW ~ 5kW) EM3G motor EC3S-A1924-XX EC3S-I1924-XX
Main circuit terminal Straight type, 6pin, 20A		ED3L driver (200VAC, 0.75kW ~ 2kW)	Motor power plug (No brake, wire)		EM3A motor (0.05kW ~ 1kW) EM3J motor EC3P-N9118-XX EC3P-N8118-XX
Control loop terminal Straight type, 5pin, 14.5A		ED3L driver (200VAC, 0.75kW ~ 2kW)	Motor power plug (With brake, wire)		EM3A motor (0.05kW ~ 1kW) EM3J motor EC3P-B9118-XX EC3P-B8118-XX
Motor power terminal Straight type, 3pin, 20A		ED3L driver (0.75kW ~ 3kW)	Motor power plug (No brake, Waterproof wire)		EM3A motor (0.05kW ~ 1kW) EM3J motor EC3P-N9718-XX EC3P-N8718-XX
Main loop terminal Straight type, 10pin, 32A		ED3L driver (400VAC, 1kW ~ 3kW)	Motor power plug (With brake, Waterproof wire)		EM3A motor (0.05kW ~ 1kW) EM3J motor EC3P-B9718-XX EC3P-B8718-XX
Encoder plug (SM-10P-B)		All drives	Motor power plug (Bending type, 9pin, 13A+23A)		EM3G motor (0.85kW ~ 1.8kW) EM3A motor (1.5kW ~ 5.0kW) EC3P-□9314-XX EC3P-□9319-XX
			Motor power plug (Bending type, 6pin, 13A+46A)		EM3G motor (2.9kW ~ 7.5kW) EC3P-□8214-XX EC3P-□9212-XX EC3P-□9211-XX